

72

72-1

72-2

2mi n Terostat-8511
 Terostat-8511

2h
 5mi n
 15mi n 4~6mm

72-3

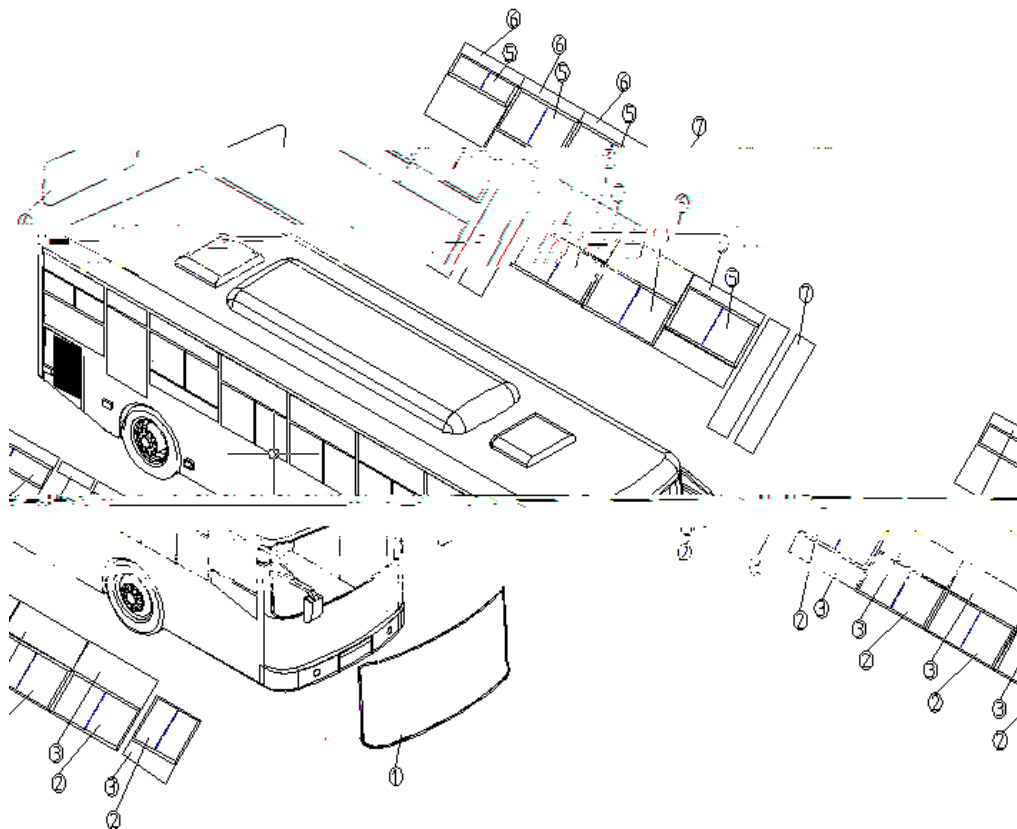

1	
2	
3	
4	
5	
6	
7	

72-4

1 (54 -)

2

(a)

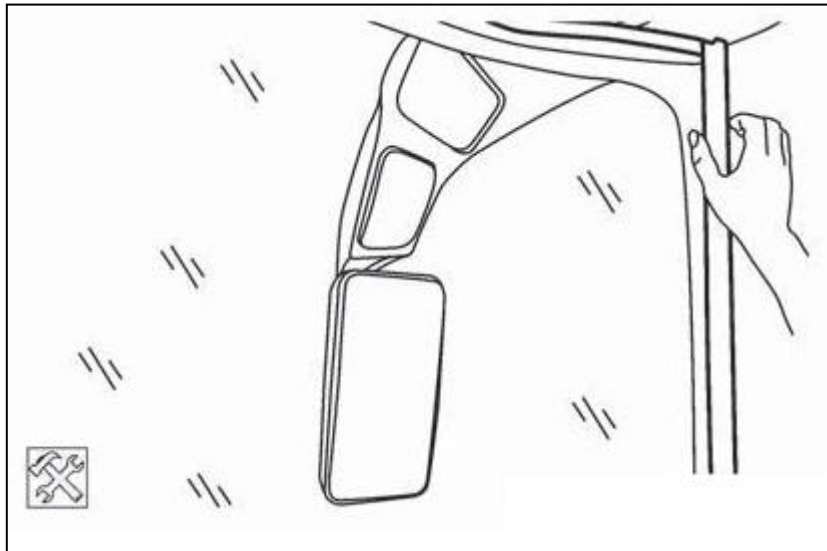

(b).

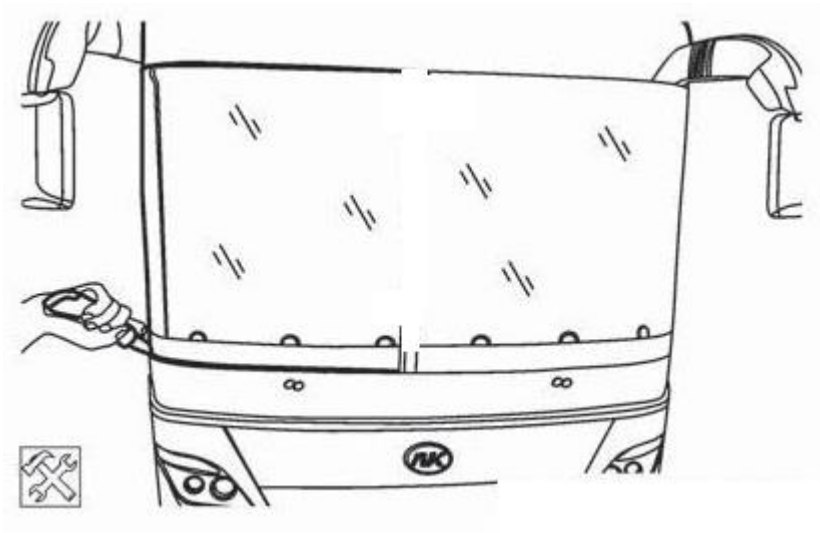

(c).

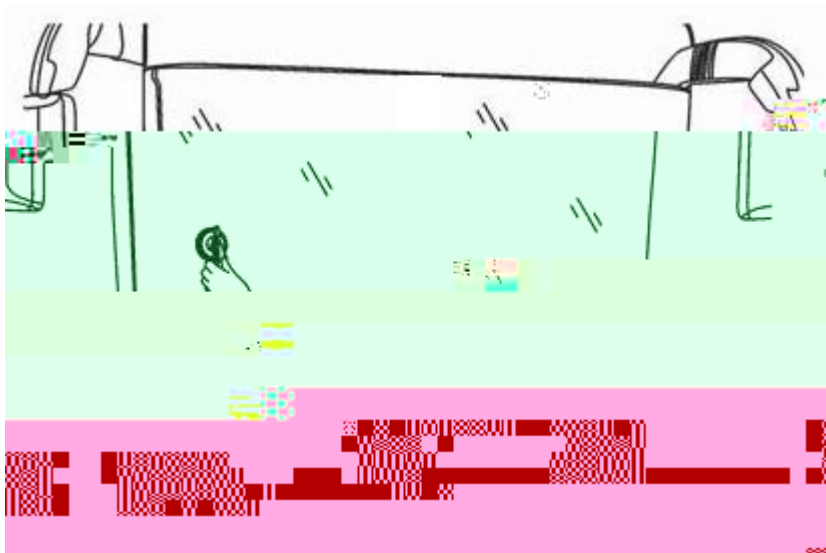

(d). 0.5mm

3.

(a).

(b).

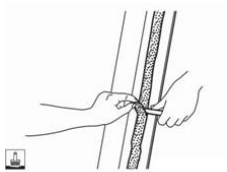

4.

- (a).
- (b).

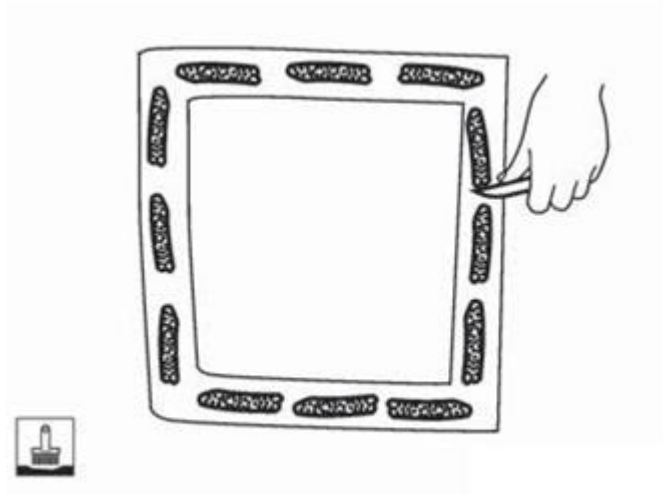

- 5.
- (a).

35mm



- (b).

15min

40-60

16-20mm

16-20mm

15min

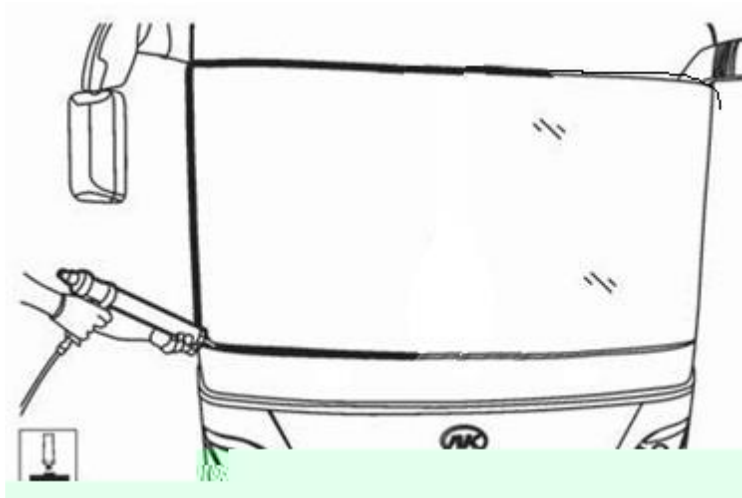

(c).

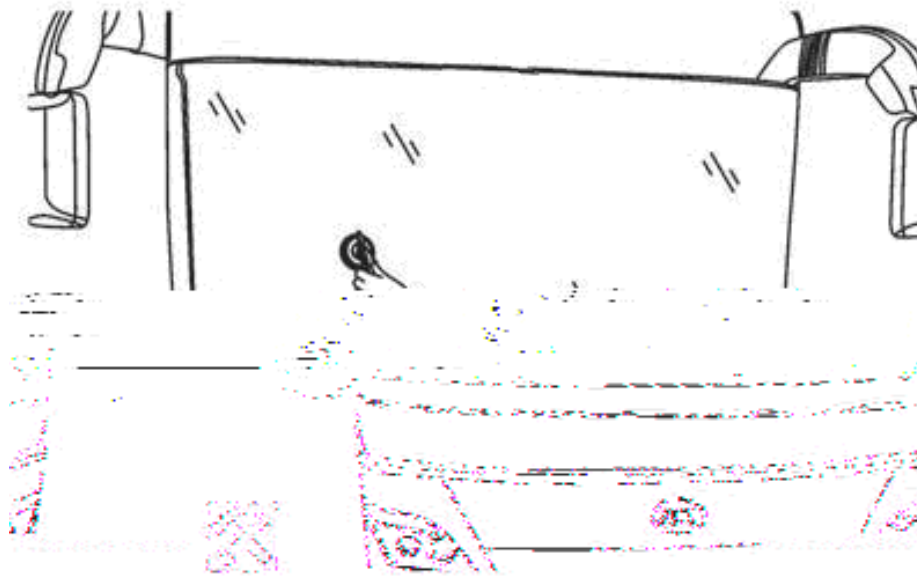

(d).

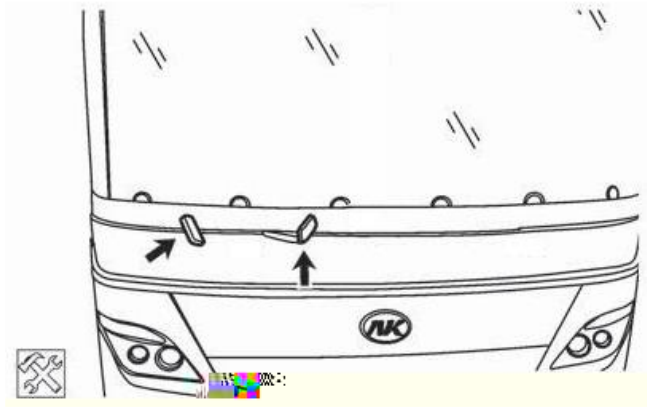

(e).

3~6mm

(f).

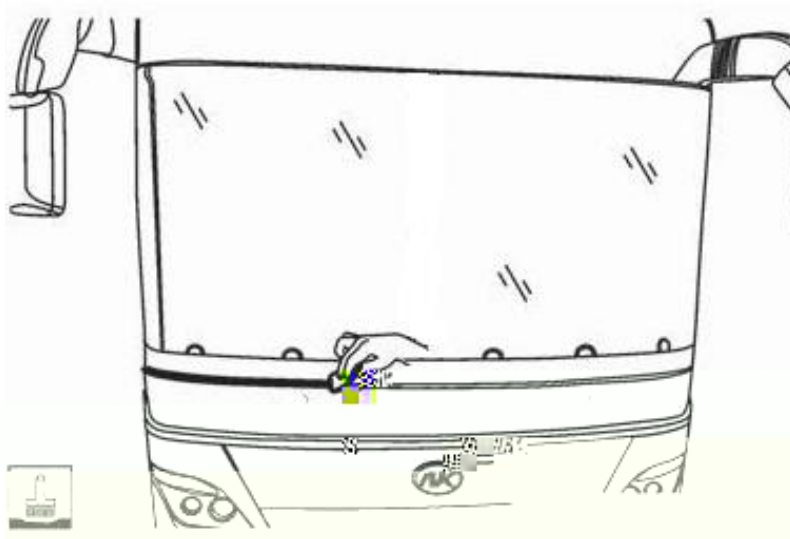

6
7

(54 -)

30min

155Kpa

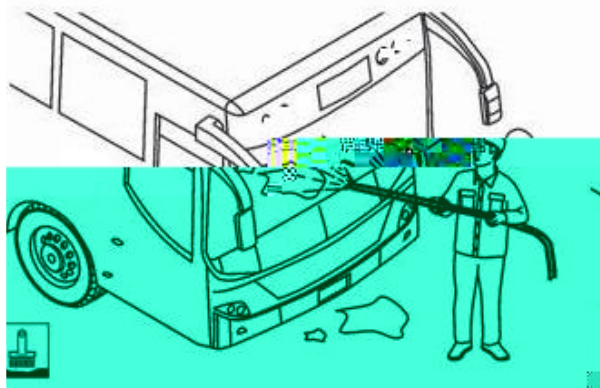

72-5

1 (/ / -)

2

(a).

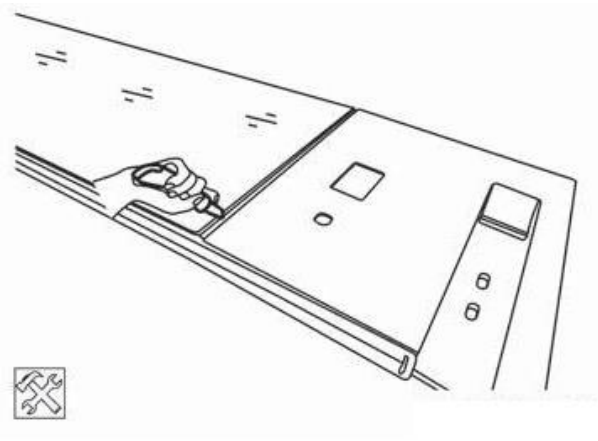

(b).

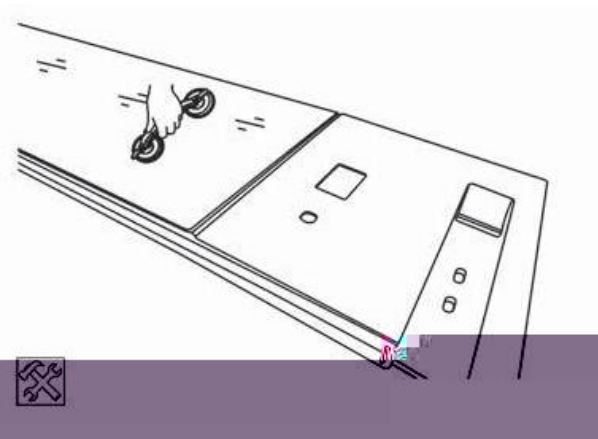

(c).

0.5mm

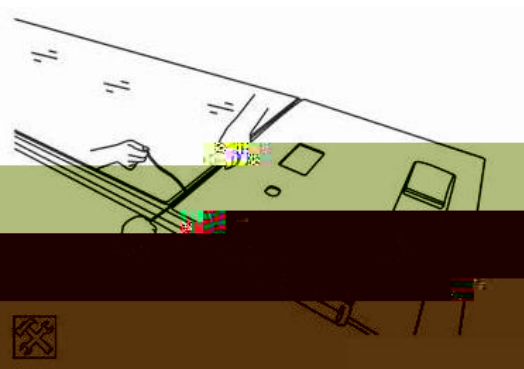

3

(a).

(b).

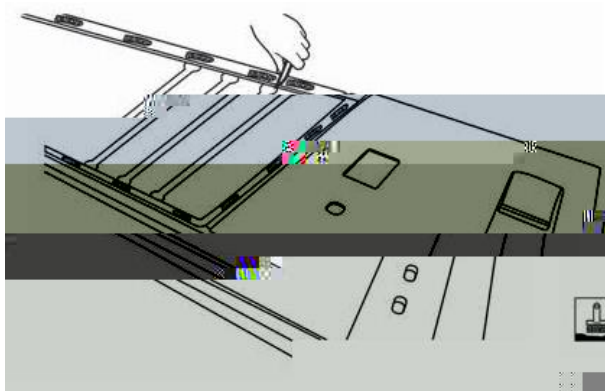

4

(a).

10min

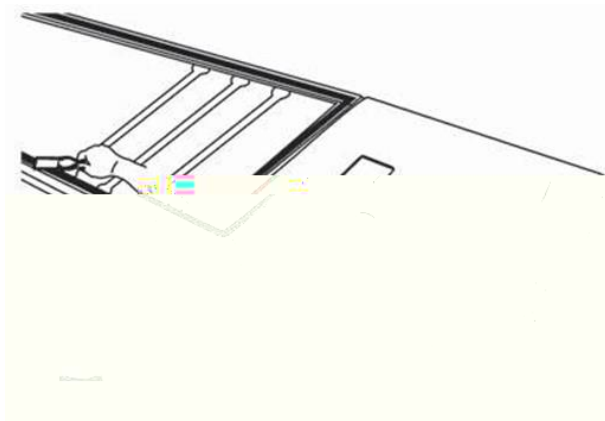

(b).

15min

40~60

16~20mm

16~20mm

15min

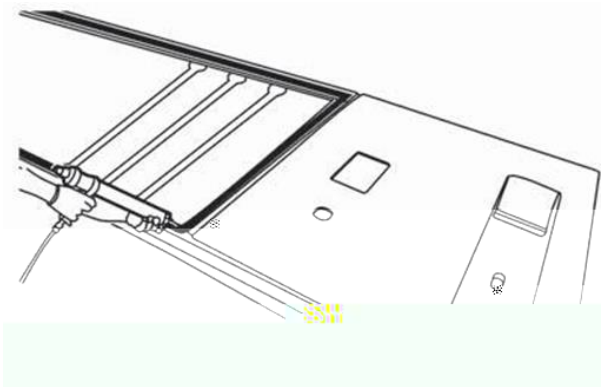

(c).

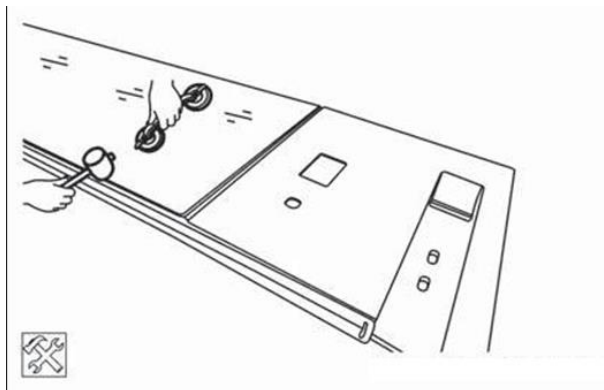

(d).

3~6mm

(e).

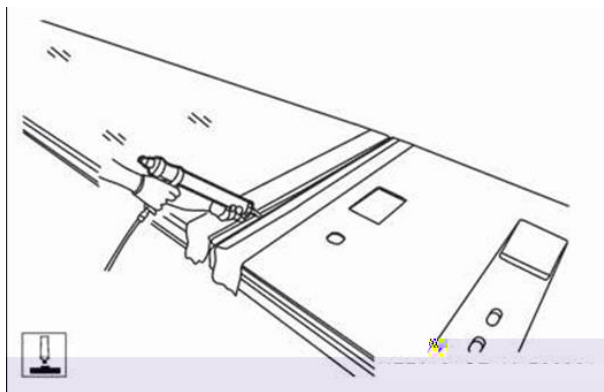

(f).

3~5h

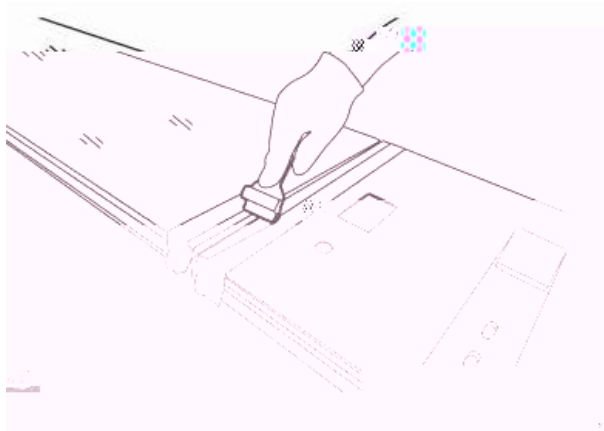

5 (/ / -)
6

72-6

1 (/ -)
2
(a).

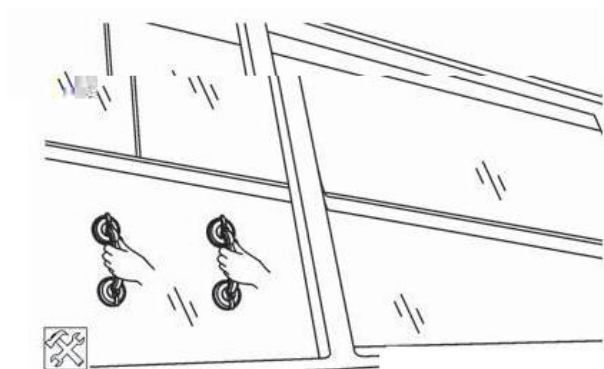

(b). 0.5mm

3
(a). 5mm

3-5mi n

3-5mi n

4h

(b).

100mm

72-6

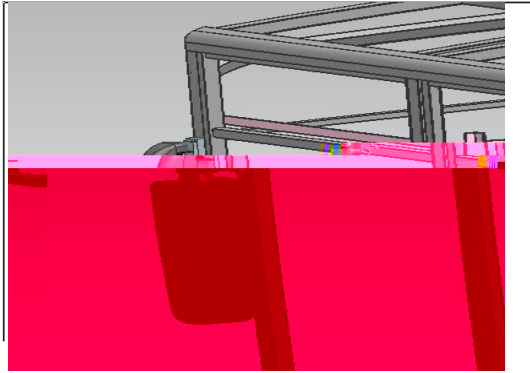

1.
 - (a).

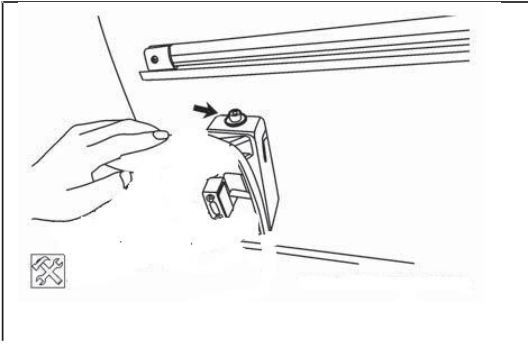

1.
(a).

(b).

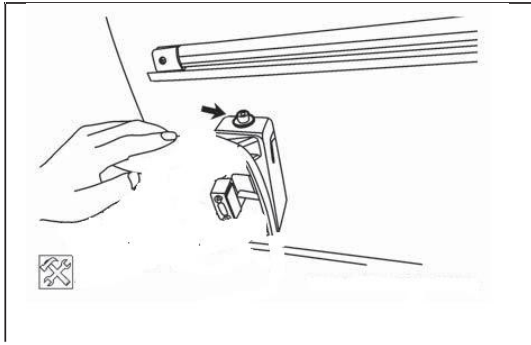

2.
(a).

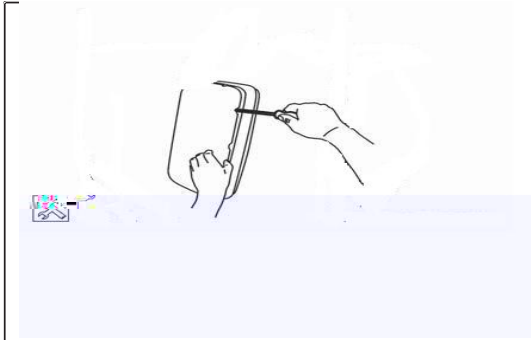

3.
(a).

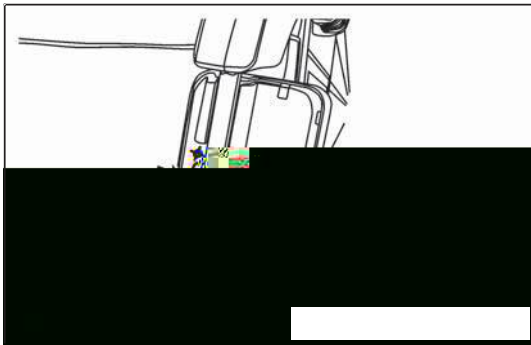

(b).

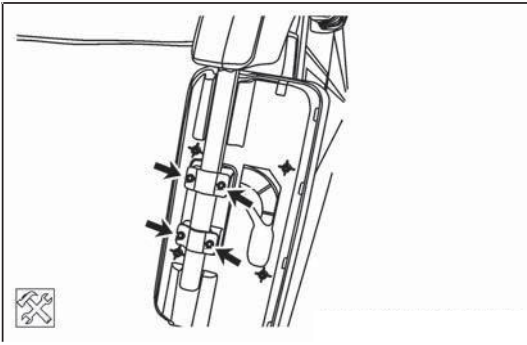

4.
(a).

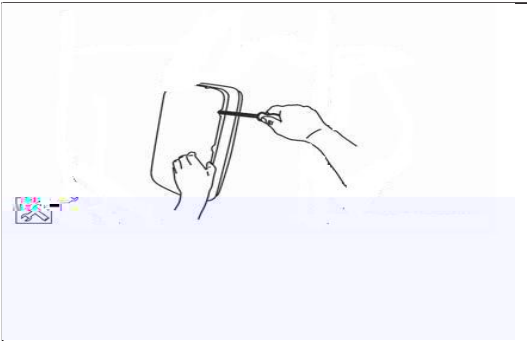

(b).

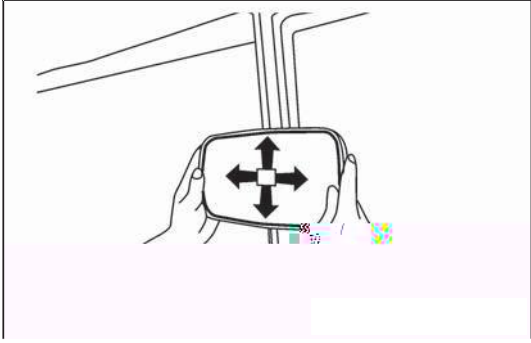

1.
(a).



/ -

1.
(a).

2.
(a).